



ENGINE

Model	Isuzu AM-4JJ1X CEGR, SCR and DOC
Emissions Certification	Tier 4 Final
Fuel	Requires ultra low-sulfur fuel B5 biodiesel tolerant
Type	Water-cooled, 4-cycle, high pressure common rail system. Turbo-charged w/ air cooled intercooler
Cylinders	4-cylinder in-line
Displacement	183 in ³ (3.0 L)
Bore/Stroke	3.76 x 4.13 in (95.4 x 104.9 mm)
Fuel injection	Direct injection – electronic
Fuel filter	Replaceable, full flow spin-on cartridge
Air filter	Dry type element w/ warning restriction indicator
Oil filter	Replaceable, full flow spin-on cartridge
Engine gradeability:	
Side-to-side	35°
Fore and aft	35°
Net horsepower – SAE J1349 @ 2000 RPM:	102 hp (76.4 kW)
Net max. torque – SAE J1349 @ 1800 RPM:	257 lb-ft (349 N-m)
Cooling operating range:	109° to -13° F (43° to -25° C)
Oil	Requires low-ash oil CJ-4

DRIVETRAIN

Travel control	Dual stage relief/ counter balance design
Brakes	Mechanical disc
Service brakes	SAHR disc – each motor
Two speed travel:	
Max. high speed	3.5 mph (5.6 kph)
Max. low speed	2.1 mph (3.4 kph)
Automatic downshift	
Drawbar pull	26,100 lbf (116 kN)
Gradeability	70% – 35° slope

ELECTRICAL

Voltage	24 Volts
Alternator rating	50 amp
Batteries	2 x 12 Volt
Battery reserve capacity	72 Ah/5 hour
Work lights – 4	24 Volt/70 watt
1 boom, 1 upper, 2 cab	

OPERATOR ENVIRONMENT

Air-conditioner output	13,492 BTU/hr
Heater output	12,897 BTU/hr
Sound level inside cab – ISO6395	70 dBA
Electrical outlet	12 Volt
Cab interior light	10 watt
Side view camera – right	Standard
Seat	Air-suspension

ATTACHMENT

Boom	15 ft 2 in (4 630 mm)
Arm	8 ft 2 in (2 500 mm)
Bucket digging force	20,200 lb-ft (90 kN)
w/ Auto Power-Boost	21,400 lb-ft (95 kN)

NOTE: *Digging force ratings based on ISO6015.

OPERATING WEIGHT

Operating weight	33,600 lb (15 200 kg)
w/ shoes	2 ft 0 in (600 mm)
w/ boom	15 ft 2 in (4 630 mm)
w/ arm	8 ft 2 in (2 500 mm)
w/ bucket	882 lb (400 kg)
w/ blade	8 ft 6 in (2 590 mm)
w/ counterweight	7,860 lb (3 570 kg)

NOTE: W/ operator/full fuel/standard equipment.

GROUND PRESSURE

@ Standard operating weight	5.9 psi (0.41 bar)
w/ 23.6 in (600 mm) triple grouser shoes,	
8 ft 2 in (2.5 m) Arm, 0.65 yd ³ (0.5 m ³) bucket	

HYDRAULICS

System design	Open center
Main pumps	Two-variable displacement/ axial piston
Max. rated flow per pump:	34.1 gpm (129 L/min) @ 2000 RPM
Max. rated flow total:	65.5 gpm (248 L/min) @ 2000 RPM
System pressures:	
Boom, arm and bucket	4,970 psi (343 bar)
w/ power boost	5,260 psi (363 bar)
Travel circuit	4,970 psi (343 bar)
Swing circuit	4,050 psi (279 bar)
Blade circuit	2,990 psi (206 bar)
Pilot pump	1 x gear design
Max. capacity	5.3 gpm (20 L/min)
Controls	w/ boom/arm holding valve
Right track travel, bucket, boom and arm acceleration.	1 x Four-spool section

Left track travel,
auxiliary, swing, boom
and arm acceleration.

1 x Five-spool section

Blade

1 x One-spool section

Work mode selections

SP: Speed Priority
H: Heavy-Duty
A: Automatic

Swing motor

Fixed displacement axial piston

Swing final drive

Planetary gear reduction

Travel motor

Two-speed independent
travel/axial piston

HYDRAULIC CYLINDERS

Boom cylinders	Two (2)
Cylinder bore	4.1 in (105 mm)
Cylinder rod diameter	3.0 in (75 mm)
Cylinder stroke	44.1 in (1 120 mm)
Arm cylinder	One (1)
Cylinder bore	4.5 in (115 mm)
Cylinder rod diameter	3.1 in (80 mm)
Cylinder stroke	43.6 in (1 108 mm)
Bucket cylinder	One (1)
Cylinder bore	3.7 in (95 mm)
Cylinder rod diameter	2.6 in (65 mm)
Cylinder stroke	34.7 in (881 mm)
Blade cylinder	Two (2)
Cylinder bore	4.5 in (115 mm)
Cylinder rod diameter	2.8 in (70 mm)
Cylinder stroke	9.8 in (250 mm)

SERVICE CAPACITIES

Fuel tank	53 gal (200 L)
Hydraulic system	42 gal (158 L)
Hydraulic tank	20 gal (75 L)
Engine oil w/ filter	4.5 gal (17 L)
Swing drive	0.6 gal (2.2 L)
Final drive	0.6 gal (2.1 L)
Cooling system	4.4 gal (16.5 L)
Def Tank	11.9 gal (45 L)

OTHER SPECIFICATIONS

Swing speed	0 – 12.5 RPM
Swing torque	27,400 lb-ft (37 000 N-m)
Swing brake	Mechanical disc
Undercarriage:	
Length	13 ft 8 in (4 160 mm)
Track gauge	6 ft 6 in (1 990 mm)
Carrier rollers – each side	1
Track rollers – each side	7
Shoes – triple grouser – each side	43
Shoe width – std.	2 ft 0 in (600 mm)
Link pitch	6.8 in (172 mm)
Track:	
Chain	Grease lubricated/strutted
Guides	Single
Adjustment	Hydraulic

BUCKETS

Application	Width	SAE Rated Capacity
Heavy-Duty Pin-On	18 in to 48 in (457 mm to 1 219 mm)	0.36 yd ³ to 1.08 yd ³ (0.28 m ³ to 0.83 m ³)
Heavy-Duty Hi-Capacity Pin-On	18 in to 42 in (457 mm to 1 067 mm)	0.42 yd ³ to 1.08 yd ³ (0.32 m ³ to 0.83 m ³)
Heavy-Duty Coupler	18 in to 48 in (457 mm to 1 219 mm)	0.31 yd ³ to 0.95 yd ³ (0.24 m ³ to 0.73 m ³)
Ditch Cleaning Pin-On	48 in to 60 in (1 219 mm to 1 524 mm)	0.64 yd ³ to 1.02 yd ³ (0.49 m ³ to 0.78 m ³)

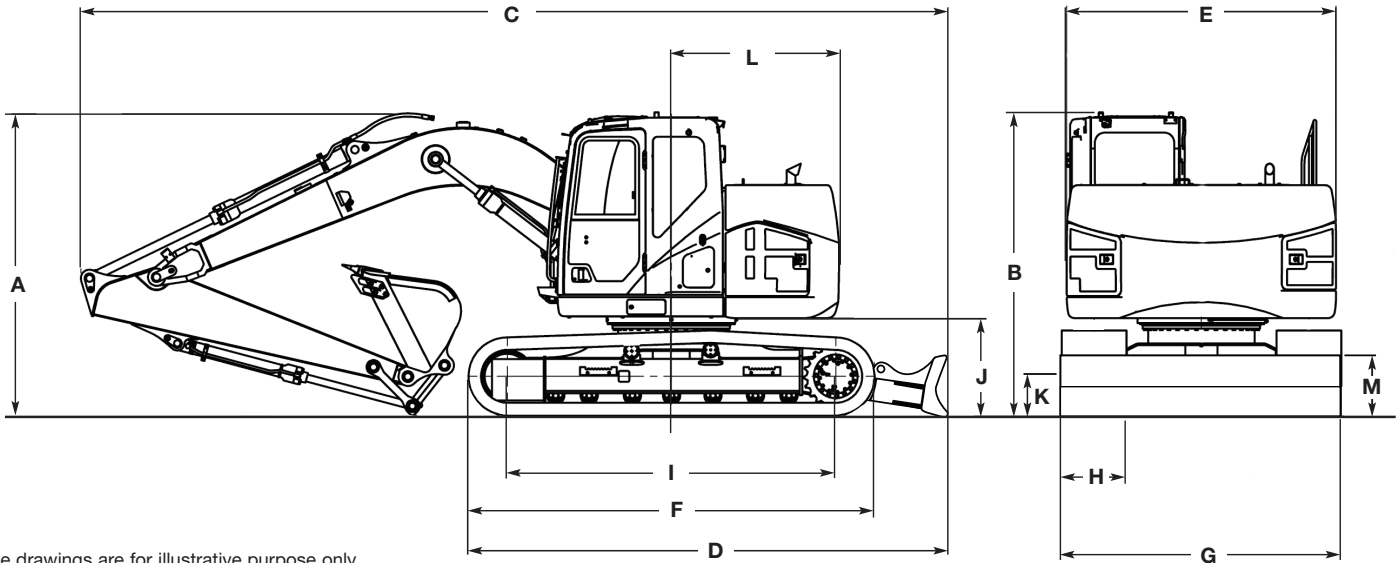

Line drawings are for illustrative purpose only and may not be exact representation of unit.

DIMENSIONS

	8 ft 2 in (2.50 m) Arm	9 ft 10 in (3.01 m) Arm	6 ft 11 in (2.11 m) Arm
A. Overall height – to top of boom	9 ft 4 in (2 840 mm)	8 ft 10 in (2 680 mm)	9 ft 0 in (2 750 mm)
B. Cab height	9 ft 3 in (2 820 mm)	9 ft 3 in (2 820 mm)	9 ft 3 in (2 820 mm)
C. Overall length – with attachment	25 ft 10 in (7 880 mm)	25 ft 9 in (7 860 mm)	25 ft 10 in (7 870 mm)
D. Overall length – without attachment	13 ft 8 in (4 160 mm)	13 ft 8 in (4 160 mm)	13 ft 8 in (4 160 mm)
E. Width of upper structure	8 ft 2 in (2 490 mm)	8 ft 2 in (2 490 mm)	8 ft 2 in (2 490 mm)
F. Track overall length	11 ft 6 in (3 500 mm)	11 ft 6 in (3 500 mm)	11 ft 6 in (3 500 mm)
G. Track overall width with 23.6 in (600 mm) shoes	8 ft 6 in (2 590 mm)	8 ft 6 in (2 590 mm)	8 ft 6 in (2 590 mm)
H. Track shoe width	2 ft 0 in (600 mm)	2 ft 0 in (600 mm)	2 ft 0 in (600 mm)
I. Center to center – idler to sprocket	9 ft 2 in (2 790 mm)	9 ft 2 in (2 790 mm)	9 ft 2 in (2 790 mm)
J. Upper structure ground clearance	2 ft 11 in (880 mm)	2 ft 11 in (880 mm)	2 ft 11 in (880 mm)
K. Minimum ground clearance	1 ft 5 in (425 mm)	1 ft 5 in (425 mm)	1 ft 5 in (425 mm)
L. Rear tail swing radius	5 ft 0 in (1 530 mm)	5 ft 0 in (1 530 mm)	5 ft 0 in (1 530 mm)
M. Blade Height	22 in (570 mm)	22 in (570 mm)	22 in (570 mm)

NOTE: *With 23.6 in (600 mm) track shoe, 1,067 lb (484 kg) bucket, 165 lb (75 kg) operator, full fuel and standard equipment.

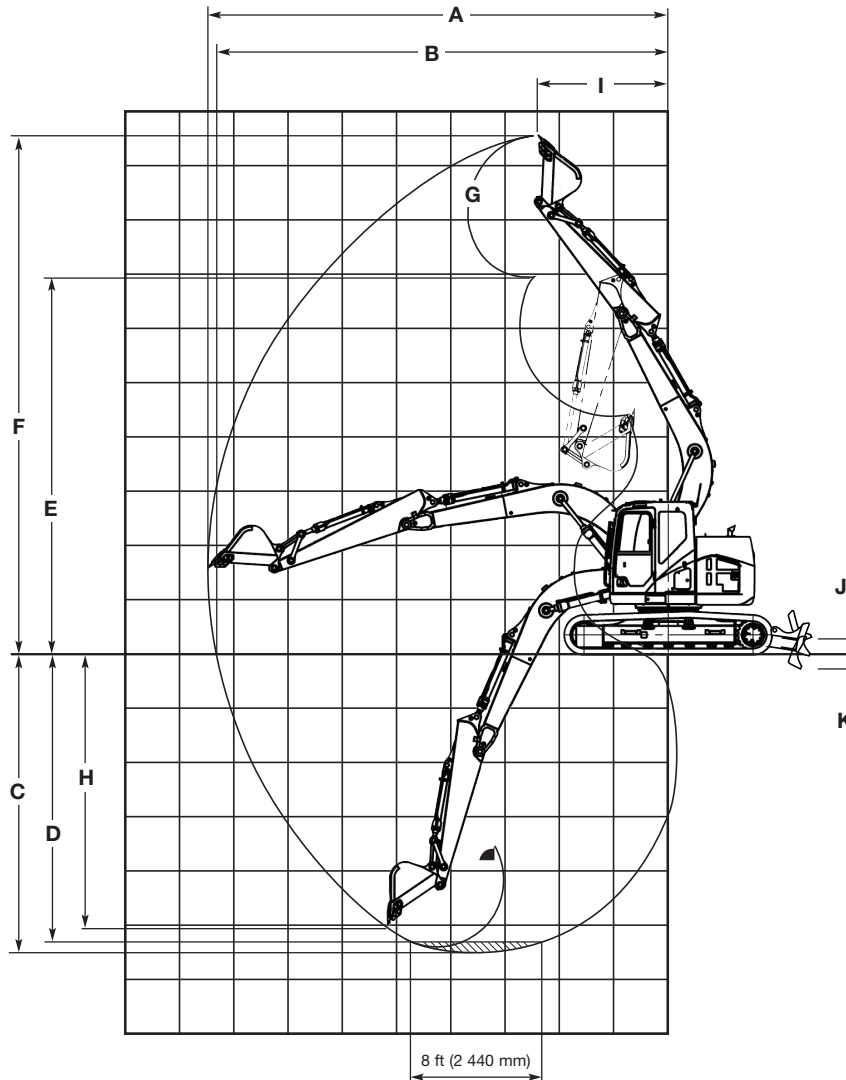

PERFORMANCE SPECS

	8 ft 2 in (2.50 m) Arm	9 ft 10 in (3.01 m) Arm	6 ft 11 in (2.11 m) Arm
A. Maximum dig radius	27 ft 2 in (8 290 mm)	28 ft 8 in (8 740 mm)	26 ft 1 in (7 940 mm)
B. Dig radius at groundline	26 ft 8 in (8 140 mm)	28 ft 3 in (8 600 mm)	25 ft 6 in (7 780 mm)
C. Maximum dig depth	18 ft 1 in (5 510 mm)	19 ft 9 in (6 010 mm)	16 ft 9 in (5 110 mm)
D. Dig depth – 8 ft 0 in (2.44 m) level bottom	17 ft 4 in (5 290 mm)	19 ft 2 in (5 830 mm)	16 ft 0 in (4 870 mm)
E. Dump height	22 ft 9 in (6 940 mm)	23 ft 11 in (7 290 mm)	21 ft 10 in (6 660 mm)
F. Maximum reach height	30 ft 8 in (9 340 mm)	31 ft 9 in (9 690 mm)	29 ft 9 in (9 060 mm)
G. Bucket rotation	178°	178°	178°
H. Maximum vertical wall dig depth	16 ft 1 in (4 900 mm)	17 ft 4 in (5 280 mm)	15 ft 0 in (4 560 mm)
I. Minimum swing radius	7 ft 8 in (2 340 mm)	9 ft 0 in (2 750 mm)	6 ft 8 in (2 030 mm)
J. Blade Maximum lift above ground	1 ft 8 in (510 mm)	1 ft 8 in (510 mm)	1 ft 8 in (510 mm)
K. Blade Minimum drop below ground	1 ft 9 in (520 mm)	1 ft 9 in (520 mm)	1 ft 9 in (520 mm)
Arm digging force:			
Standard	13,900 lbf (62 kN)	12,600 lbf (56 kN)	15,700 lbf (70 kN)
Power Boost	14,800 lbf (66 kN)	13,500 lbf (60 kN)	16,600 lbf (74 kN)
Bucket digging force:			
Standard	20,200 lbf (90 kN)	20,200 lbf (90 kN)	20,200 lbf (90 kN)
Power Boost	21,400 lbf (95 kN)	21,400 lbf (95 kN)	21,400 lbf (95 kN)

STANDARD EQUIPMENT

ENGINE

Isuzu four-cylinder turbo-charged diesel
Tier 4 Final – CEGR, DOC, SCR
Electronic fuel injection
High pressure common rail system
Diesel Oxidation Catalyst System (DOC)
Neutral safety start
Auto-engine warm up
Glow-plug pre-heat
EPF (Engine Protection Feature)
Dual-stage fuel filtration
Dual element air filter
Remote oil filter
Green plug oil drain
500-hour engine oil change interval
24-volt system
Requires CJ-4 engine oil
Requires ultra low-sulfur fuel

FUEL ECONOMY SYSTEMS

Engine Idle/Fuel Economy System:
Auto-idle
One-touch idle
Auto-idle shut-down
BEC – Boom Economy Control
AEC – Auto Economy Control
SWC – Swing Relief Control
SSC – Spool Stroke Control

HYDRAULICS

Auto power boost
Auto swing priority
Auto travel speed change
Selectable work modes
ISO pattern controls
Pre-set auxiliary pump settings
Auxiliary valve
5,000-hour hydraulic oil change interval
1,000-hour hydraulic filter change interval
SAHR brake
Free Swing
Control Pattern Selector

OPTIONAL EQUIPMENT

HYDRAULICS

Auxiliary hydraulics:
Single acting/joystick activated
Double acting/joystick activated
Multi-function/joystick activated
Secondary low-flow/joystick activated

MACHINE CONTROL

Leica iCON iXE2 – 2D System
Leica iCON iXE3 – 3D System

UPPER STRUCTURE

Right and left side mirrors
Isolation mounted cab (fluid and spring)
Common key vandal locks
Upper mounted work light (70 watt)
Swivel guard belly pan

ATTACHMENTS

Boom – 15 ft 2 in (4.63 m)
Arm – 8 ft 2 in (2.50 m)
Heavy-duty bucket linkage
Boom mounted work light (70 watt)
Auxiliary pipe brackets
Centralized grease fittings
Attachment cushion valve
Foldable hand rails
Arm and boom regeneration

OPERATOR ENVIRONMENT

ROPS protection
FOPS cab top guard (Level 1)
Pressurized cab
One-touch lock front window
AC/heat/defrost with auto climate control
Color monitor – 7 in (180 mm)
Interior dome light
Air-suspension seat (cloth)
Seatbelt – 3 in (76 mm)
Adjustable armrests
Tilting consoles – 4-position
Low-effort joystick controls
Sliding cockpit – 7 in (180 mm)
Straight travel
AM/FM Radio with Bluetooth, antenna
and two speakers
Aux-in port for personal electronics
Rear-view camera
Anti-theft system (start code system)
Side view camera – right
Rubber floor mat
12-volt electric outlet

ATTACHMENTS

Standard arm – 9 ft 11 in (3.01 m)
Heavy-duty arm – 6 ft 10 in (2.11 m)
Coupler/Case multi-pin grabber
Buckets:
Heavy-duty
Extreme-duty
Load holding control
Hose Burst Check Valve (HBCV)

UNDERCARRIAGE

27.6 in (700 mm) steel shoes,
triple semi-grouser
20.0 in (500 mm) rubber shoes
Double track chain guides

24-volt cigarette lighter
External rearview mirrors
Windshield wiper/washer
Clear (polycarbonate) roof window
with sunshade
Cup holder
Storage compartments
On-board diagnostic system
Travel alarm with cancel switch
One key start and lock-up

UNDERCARRIAGE

23.6 in (600 mm) steel shoes,
triple grouser
Full overlap turntable bearing hub
Hydraulic track adjustment
X-pattern carbody

DOZER BLADE

Front dozer blade – 8 ft 6 in (2.59 m) width,
22 in (570 mm) height, comes with 23.6 in
(600 mm) steel shoes

TELEMATICS

CASE SiteWatch™ Telematics – includes
hardware and a 3-yr Advanced
data subscription

OPERATOR ENVIRONMENT

FOPS cab top guard (Level 2)
Front grill guard – 2 x 2 screen mesh
Front rock guard – vertical bars
(two piece)/OPG 1
Front rock guard – vertical bars
(fixed/one piece)/OPG 2
Vandal guard
Rain deflector
Sun visor
Side-view camera
Refueling pump

©2021 CNH Industrial America LLC. All rights reserved. CASE is a trademark registered in the United States and many other countries, owned by or licensed to CNH Industrial N.V., its subsidiaries or affiliates. CNH Industrial Capital is a trademark in the United States and many other countries, owned by or licensed to CNH Industrial N.V., its subsidiaries or affiliates. Printed in U.S.A. Contains 10% post-consumer fiber.

Form No. **CCE202106CX145DSRDB**
Replaces Form No. CCE201807CX145DSRDB

CX145D SR DB

IMPORTANT: CASE Construction Equipment Inc. reserves the right to change these specifications without notice and without incurring any obligation relating to such change. Availability of some models and equipment builds vary according to the country in which the equipment is used. The illustrations and text may include optional equipment and accessories and may not include all standard equipment. Your CASE dealer/distributor will be able to give you details of the products and their specifications available in your area.



CASE Construction Equipment is biodiesel-friendly. NOTE: All engines meet current EPA emissions regulations. All specifications are stated in accordance with SAE Standards or Recommended Practices, where applicable.



Always read the Operator's Manual before operating any equipment. Inspect equipment before using it, and be sure it is operating properly. Follow the product safety signs and use any safety features provided.