

TB2150R

HYDRAULIC EXCAVATOR



Operating Weight ■ CAB (RUBBER) 34,215 lb CAB (STEEL) 34,435 lb
Dig Depth ■ 19 ft 9.4 in
Max Reach ■ 28 ft 10.1 in

TOUGH. POWERFUL. RELIABLE.

The TB2150R is one of the largest excavators in the Takeuchi line up. It features a fixed boom design that provides excellent visibility to the work equipment, greater stability, and it allows the operator to lift heavy loads efficiently. With its standard long arm, the TB2150R has an excellent working range and the standard thumb mount makes it easier and more convenient to install a hydraulic thumb increasing the machines capability. A 113.9 hp engine delivers exceptional performance while meeting the very latest US EPA Final Tier IV emissions standards. A redesigned operator's station features an intuitive 7" multi-function color display, a deluxe high back air suspension seat, AM/FM radio with Bluetooth, and rocker switches for a wide range of functions. Additionally, the TB2150R has a 270 degree camera system for greater peace of mind and an excellent LED light package for low light conditions. Three auxiliary hydraulic circuits including high flow of 59 gpm on the primary circuit are standard equipment on the TB2150R making it the perfect platform for a wide range of hydraulically powered attachments.



PRODUCT FEATURES & SPECIFICATIONS

ENGINE

- Automatic Fuel Priming System
- Dual Element Air Cleaner
- Working Modes: Standard/ECO/High Altitude
- Automatic Cold Start Device
- Variable Speed Hydraulic Fan
- Engine Safe Start System

ELECTRICAL

- Rear and Side View Cameras
- Sealed Rocker Switches
- Deluxe LED Light Package

OPERATOR'S STATION

- Cab w/ Air Conditioner, Heat, Defrost, Windshield Wiper and Washer, Polycarbonate Skylight with Sunshade, AM/FM/Bluetooth Radio, 24v and 12v Power Outlet
- ROPS/OPG Level 2
- Protection
- Adjustable Arm Rests
- 2" Retractable Seat Belt
- Roof Guard
- Front Window Guard (optional)

UNDERCARRIAGE AND FRAME

- Triple Flanged Track Rollers
- 2-Speed Axial Piston Travel Motors with Counter Balance Valves
- Load Sensing Automatic Shift Down
- Automatic Slew Brake w/ Shock-less Relief Valve
- High Torque, Final Planetary Drives
- Heavy Duty Backfill Blade with Float

HYDRAULIC & WORKING EQUIPMENT

- Cushioned Boom and Arm Cylinders
- Arm and Boom Holding Valve with Lift Alarm
- Long Arm with Thumb Mount
- Pattern Change Valve (ISO or SAE)
- High Capacity Hydraulic Oil Cooler
- Hydraulic Pilot Controls
- Pilot Accumulator

TAKEUCHI FLEET MANAGEMENT

- Minimize Downtime
- Remote Diagnostics
- Utilization Tracking
- Proactive Maintenance
- Control Costs



Spacious Operator Station



Images may show optional equipment.
Please consult your Takeuchi dealer for details.

OPERATING PERFORMANCE

Operating Weight - Cab (Rubber)	34,215 lb	(15,520 kg)
Operating Weight - Cab (Steel)	34,435 lb	(15,619 kg)
Operating Weight - Cab (Segmented Rubber)	34,403 lb	(15,605 kg)
Maximum Bucket Breakout	22,256 lbf	(10,095 kgf)
Digging Force	13,490 lbf	(6,119 kgf)
Arm Length	8 ft 3.6 in	(2,529.8 mm)
Slew Speed	11 rpm	
Traction Force	35,230 lbf	(15,980 kgf)
Ground Pressure - Cab (Rubber)	6.6 psi	(45.5 kPa)
Ground Pressure - Cab (Steel)	6.7 psi	(46.1 kPa)
Ground Pressure - Cab (Segmented Rubber)	6.7 psi	(46.1 kPa)
Max Travel Speed		
Low Range	1.8 mph	(2.9 km/h)
High Range	3.4 mph	(5.5 km/h)

ENGINE

Make/Model	Deutz / TCD 3.6 L4	
Displacement	221.0 cu in	
Horsepower @ 2,000 rpm	114.0 hp	
Maximum Torque @ 1,600 rpm	338 ft-lb	

FLUID CAPACITIES

Engine Lubrication	10.6 qt	(10 L)
Cooling System	28.5 qt	(27 L)
Fuel Tank	58.4 gal	(221 L)
DEF Fluid Tank Capacity	5.3 gal	(20 L)
Fuel Consumption (65% of Full Load)	3.88 gph	(14.7 Lph)
Hydraulic Reservoir	26.9 gal	(102 L)

HYDRAULIC SYSTEM

Total Hydraulic Flow	78.9 gpm	(298.7 L/min)
Auxiliary Flow - Primary Circuit	59.2 gpm	(224.1 L/min)
Auxiliary Flow - Secondary Circuit	14.5 gpm	(54.9 L/min)
Hydraulic System Pressure	4,974 psi	(34.3 MPa)



ATTACHMENTS

Takeuchi offers attachments for all your Takeuchi equipment. See your authorized Takeuchi dealer for additional information and attachment options.



Multiple maintenance doors allow easy service access

MACHINE DIMENSIONS

MACHINE DIMENSIONS			
A	Maximum Reach	28 ft 10.1 in	8,791 mm
B	Maximum Reach at Ground Level	28 ft 5.2 in	8,666 mm
C	Maximum Digging Depth	19 ft 9.4 in	6,030 mm
D	Maximum Vertical Digging Depth	18 ft 1 in	5,515 mm
E	Maximum Dig Height	31 ft 7 in	9,630 mm
F	Maximum Dumping Height	23 ft 6.4 in	7,170 mm
G	Front Swing Radius	8 ft 6.8 in	2,610 mm
H	Slew Radius	5 ft 7 in	1,700 mm
I	Transport Length	25 ft 6.5 in	7,785 mm
J	Transport Height	9 ft 8.5 in	2,959 mm
K	Ground Clearance	18.7 in	475 mm
L	Track Overall Length	12 ft 5.4 in	3,795 mm
M	Track Width (Rubber)	19.7 in	500 mm
N	Track Overall Width	8 ft 2.0 in	2,489 mm

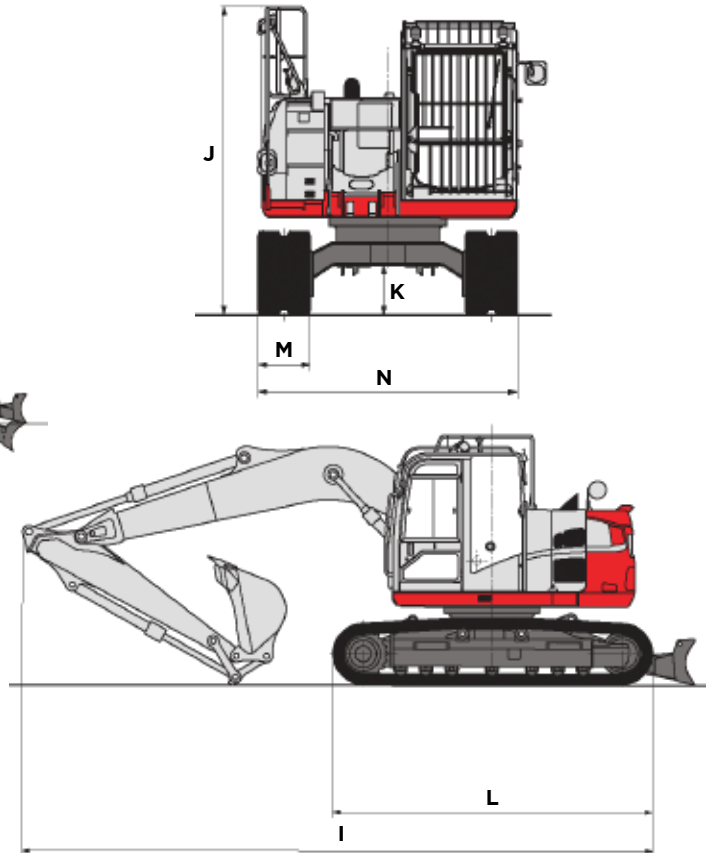
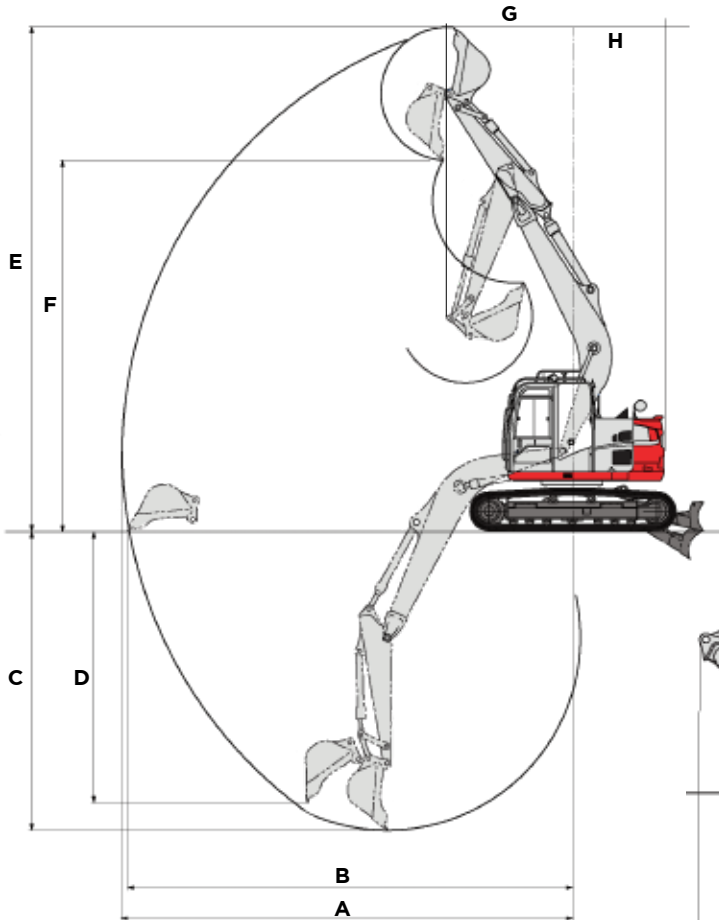

TAKEUCHI

TB2150R

519 BONNIE VALENTINE WAY

PENDERGRASS, GA 30567

706.693.3600

©2023 Takeuchi Manufacturing [U.S.], Ltd. All Rights Reserved. Printed in the U.S.A.
In accordance with our established policy of continued improvement.
FORM: TB2150R Compact Excavator Spec Sheet - July 2023